

FrostByte

Cryoquip engineers a unique heat exchanger with very high thermal efficiency

Cryoquip was recently challenged by an industrial chemical process company who uncovered a process problem that had not been anticipated in theoretical evaluation. The issue at hand involved a much higher-than-anticipated temperature of an oxygen gas stream from a reaction vessel. The gas temperature had to be lowered significantly, and quickly, before the gas could be used again in a secondary process reaction. A very limited cooling source was available in the form of a propylene glycol stream and there was very little physical room to fit a thermal heat exchanger into the crowded process equipment area.

Cryoquip engineers designed a vertical, low velocity, counter current, multi-tube heat exchanger. The heat exchanger's classic counter current design enabled the engineers to take full advantage of the limited refrigeration contained in the 65° F (18.33° C) glycol stream available. Very high thermal efficiency was achieved by designing the unit in this configuration and by carefully controlling the flow of the refrigerant through the specially-designed heat exchanger internals.

The heat exchanger was conceived, designed, approved and manufactured in just a few weeks to minimize downtime. It was designed and built in accordance with the ASME Section VIII pressure vessel code and cleaned in accordance with the gas company's stringent specifications for equipment in oxygen service.

For more information contact Bryan Smith at Cryoquip, tel +1.909.677.2060 or bsmith@cryoquip.com.

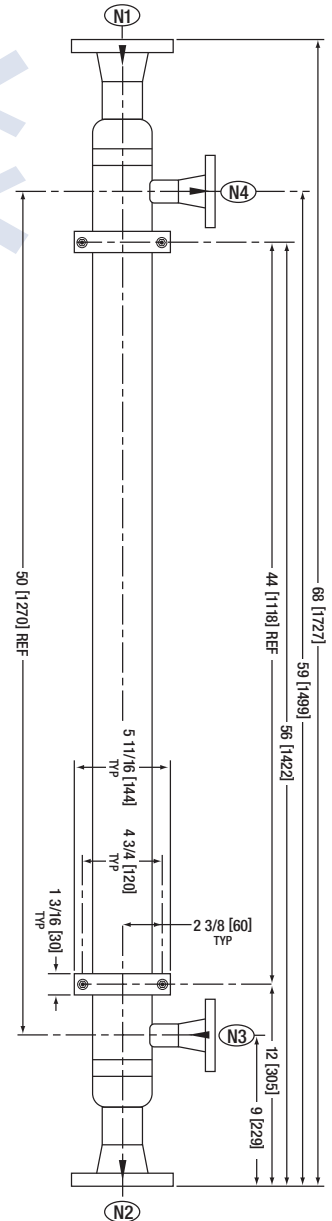
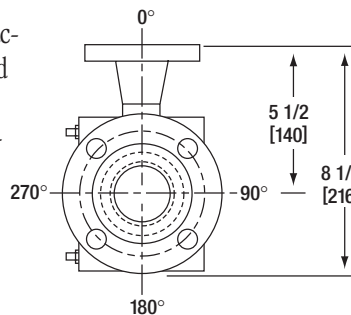

High flow and minimal footprint dictate an innovative ambient air vaporizer design	2
Cosmodyne Samplers approved for Europe	3
Climate affects the selection of ambient air vaporizers	4-5
The ACD submerged pump is ideal for many applications	6
Members of Cryogenic Industries	7
Calendar of Events	back



High flow and minimal footprint dictate an innovative ambient air vaporizer design

Cryoquip recently delivered four of the largest ambient air vaporizers the company has made to a leading gas company in Taiwan. Faced with the need to continuously vaporize 380 mtd of liquid (approximately 10,000 Nm³/hr) for a high purity nitrogen application, and with real estate at a premium, the gas company sought to come up with an economic solution, based on ambient air vaporization. A high flow system occupying a minimal footprint and maximizing heat transfer surface area was required.

Eight years ago Cryoquip introduced the UNIFLO® series, wide spaced vaporizer concept, an innovative, entirely new, patented* concept in non-defrostable natural draft ambient vaporizers, designed for ambient air vaporization and superheating of large quantities of cryogenic fluids. As flow rates steadily increase, the demand for ambient vaporizers approaching 100% continuous duty, and not requiring a defrost cycle, increases. However, this leads to concerns regarding the strength of such ambient air vaporizers and the desire for a more predictable, manageable, and acceptable ice accumulation pattern. The UNIFLO® answers all the questions regarding the physical strength of ice-laden vaporizers and the design complies with the Uniform Building Code (UBC), 100 mph wind loads, seismic zone 4 classification, the ANSI A58.1 code, and the European ENV 1991-2-4 BS CP3 (NV65) code.

In operation, the UNIFLO® vaporizer has an entirely different ice accumulation pattern compared to conventional designs. This pattern provides a sound mechanical design eliminating problem thermal stresses characteristics of conventional designs and results in more efficient heat transfer.

The UNIFLO® ambient air vaporizer has significant advantages over conventional designs for extended service:

- All the heat transfer elements are connected in parallel, which eliminates the differential thermal gradients between extrusions, and permits a true composite beam structural design. The need to compensate for thermal expansion and contraction gradients in the lateral plane is eliminated. All extrusions are at essentially the same temperature at any given vertical elevation.
- Because of the true counter-flow between the downward flow of air in natural convection and the upward flow of the cryogen in the vaporizer extrusion, the thermal performance improves by as much as 10% compared to conventional designs with the same surface area.
- Ice accumulation during continuous operation occurs in the lower part of the vaporizer, with un-iced extrusions protruding out of the ice pack. This eliminates the large ice pack at the top end of the vaporizer, which questions the mechanical strength of the vaporizer and causes customer concern. The low ice build-up lowers the center of gravity and, therefore, reduces structural requirements in meeting the UBC.
- The UNIFLO® vaporizer has a specially designed, patented*, internal configuration that results in forced convection heat transfer coefficients in excess of those in conventional series parallel flow configurations. This provides the customary approach temperature desired, with increased performance. The new UNIFLO® design incorporates a hydraulic diameter-to-length aspect ratio and net free flow area characteristics that result in a high Reynolds number with a correspondingly high internal heat transfer coefficient, per foot of extrusion length. In addition, the surging normally

accompanying low pressure drop cryogenic vaporizers is minimized. A range of models is available with continuous extrusion lengths of up to 40 feet (13 meters).

However, even the largest UNIFLO® vaporizer in the range would not meet the flow requirements of this project within the physical allowable space. A special UNIFLO® vaporizer was designed to meet the stringent application parameters, but at the same time remain small enough to fit inside an ocean container for transport to Taiwan. Four units were fabricated to meet the project requirements. In order to maximize the heat transfer surface area and minimize the vaporizer footprint, a very special all-aluminum, multi-fin heat transfer element was designed incorporating twice the normal number of fins, doubling the surface area per unit length. The elements were lined with an SA249-304 stainless steel liner to comply with the requirements of vaporizers in high purity nitrogen service. Return bends of similar material were automatically TIG orbital welded to the liners to ensure mechanical integrity at cryogenic temperatures and at elevated pressure. The liners were hydraulically expanded into the aluminum heat transfer elements to ensure intimate contact between the liner and the element to maximize the heat transfer coefficients. This construction method is unique to Cryoquip and it ensures the minimum heat transfer surface area is employed to vaporize the required quantity of gas.

The finished vaporizers each weighed 10 tons, were over 14 meters tall, but only occupied a 2.3 meter square area. Cryoquip has over 30 UNIFLO® vaporizers in service throughout the world and recently supplied two more units into Europe for similar space saving reasons.

For more information contact Bryan Smith at Cryoquip, tel +1.909.677.2060 or bsmith@cryoquip.com.

Cosmodyne Samplers approved for Europe

In the fall of last year the Cosmodyne Cryogenic Sampler was qualified by TÜV Rheinland under the European Directive for Transportation Pressure Equipment (TPED 1999/36/EC) allowing importation into Europe. The units will now carry the TPED stamp.

Cosmodyne's Type TTU-131/E Cryogenic Sampler is a device designed to draw a liquid sample into its integral vessel where it is converted to gas. The Cosmodyne shielded cup sampling method prevents contamination and permits an accurate analysis of the gas purity. (See Figure 1 for flow schematic.)

The Cosmodyne Sampler is suitable for all cryogenics, including liquefied natural gas. The unit is equipped with a burst disc and pressure gauge and a case that requires no overpacking for shipment. Optional accessories include six foot convoluted or insulated convoluted metal hoses for LH₂ applications.

For more information contact Tony Chapman at Cosmodyne, tel +1.310.320.5650 or achapman@cosmodyne.com. Descriptive literature is available at www.cosmodyne.com.

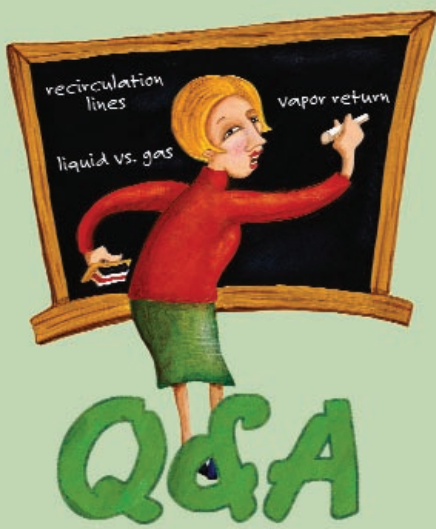
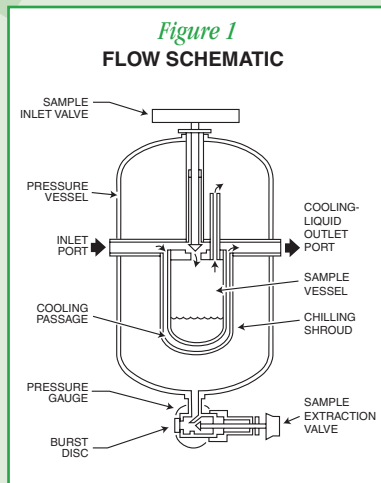

Q: Which factors are most important when selecting cryogenic pumps?

- *Price
- *Availability
- *Increased pump run life
- *Increased reliability
- *Low maintenance costs

A: Rather than focusing on criteria to optimize pump operation, some specification engineers and pump manufacturers erroneously base decisions on price and availability. As a result, the selected pump may not perform properly and may even fail.

The following pump selection checklist will aid in optimizing the pump's opportunity to meet system goals:

- 1) pumped fluid compatibility
- 2) define system NPSHA (net positive suction head available) versus the pump's NPSHR (net positive suction head required)
- 3) determine, define, and communicate the key performance requirements
- 4) consider cost of maintenance
- 5) select the appropriate flow control devices
- 6) consider piping design in terms of pump performance
- 7) consider pump installation requirements and techniques

Please forward your questions or comments to info@cryoind.com.



Climate affects the selection of ambient air vaporizers

Many factors need to be considered when designing ambient air vaporizers. The environmental effect is one such criteria. When designing and specifying fan assisted and natural draft ambient air vaporizers, we use four main climate zones: tropical, Mediterranean, humid continental, and marine. Each of these zones, however, may contain micro climate zones where the climate may be significantly different than the weather around it.

In discussing climatic effects, a basic understanding of the principles of ambient air vaporizers is necessary. Fan-assisted vaporizers utilize forced convective heat transfer where natural draft ambient air vaporizers utilize natural convective heat transfer. Natural convective vaporizers typically are manufactured with three different fin spacings, depending on how long the vaporizers are going to be operated before complete defrost is achieved. Standard spaced vaporizers typically operate less than 24 hours before complete defrost and have a fin tip-to-tip air gap roughly 1.5" (38 mm). (Figure 1)

Wide gap natural convection vaporizers generally are designed to operate three to seven days without defrost and typically have a fin tip-to-tip air gap spacing of 3" (75 mm) or more. (Figure 2) Super-wide spaced ambient air vaporizers are designed to operate continuously, with the possibility of manual defrost required several times per year. These vaporiz-

ers have a typical fin tip-to-tip spacing of 10" (254 mm) or more. (Figure 3) Forced convective vaporizers are designed with maximum heat transfer area in a minimum space. They typically have fin tip-to-tip air gap spacing of less than 1.5" (38 mm). (Figure 4)

Natural draft ambient air vaporizers operate on the principal of natural convective heat transfer. Air is cooled as gravitational force pulls it past the heat exchanger fins. It therefore becomes more dense and heavier. This density further promotes a downward motion due to gravitational effects. Forced convective heat transfer vaporizers rely on mechanical fan driven forced stimulation movement of the air, therefore not relying on gravity.

The following are basic vaporizer design considerations dealing with the location and duration of operation of ambient air vaporizers. Certainly other considerations must also be reviewed, such as electrical/fuel requirements and availability of land or real estate, proximity to roads, walkways, driveways and occupied businesses or housing.

Tropical Climate Zones

For the purpose of specifying vaporizers, tropical climate zones include equatorial regions such as Malaysia, Thailand, Indonesia, Panama, Venezuela, and Brazil. Other regions such as Japan and the southern United States replicate this climate zone closely in their summer months or monsoon season, but are generally closer to the humid continental zone. Tropical climate zones are characterized by dew point temperatures greater than 70°F (21°C). Dry bulb temperatures generally range from 80°F (27°C) to 95°F (35°C) year round. There typically is not a wide variation in the temperature between night and day, since the high moisture

content of the atmosphere tends to trap the infrared radiation emitted by objects at night, not allowing it to escape to outer space.

Both natural and fan-assisted draft ambient air vaporizers should be considered in tropical climates due to the large ambient air temperature driving force available. Flow rates under 57,000 scfh (1500 Nm³/hr) are likely to perform more economically with natural convection units; flow rates over 152,000 scfh (4000 Nm³/hr) with forced convection units. The main advantage of these systems is maximum vaporization capacity at minimal or no operation cost coupled with maximum reliability.

In order to maintain maximum vaporizer capacity from both types of vaporizers in this zone, the vaporizers should be switched quite often. Typical switching cycles would be about every four to eight hours. This is due to the high moisture content in the atmosphere and therefore rapid ice growth formation on the fins which rapidly reduces the overall heat transfer coefficient. Switching less than every two hours to obtain even more vaporization capacity is both unrealistic and dangerous. Both the natural and forced draft vaporizers will defrost adequately in this climate zone without any external energy source as long as the off cycles are at least half the duration of the on cycles. The fan driven units will assist in this process.

A system can be designed with a larger approach temperature (approach temperature is defined as the difference between ambient temperature and discharge gas temperature), because of the consistently warm temperature at night and during the day. Resulting in greater capacity from a system rated for less in other climate zones.

Mediterranean Climate Zones

Mediterranean climate zones would include areas such as the southern and central coast of California, Greece, the Algerian Coast, and other areas like Italy and Israel. Typically, these regions are characterized by precipitation periods of about four months per year. This climate zone, like the tropical climate

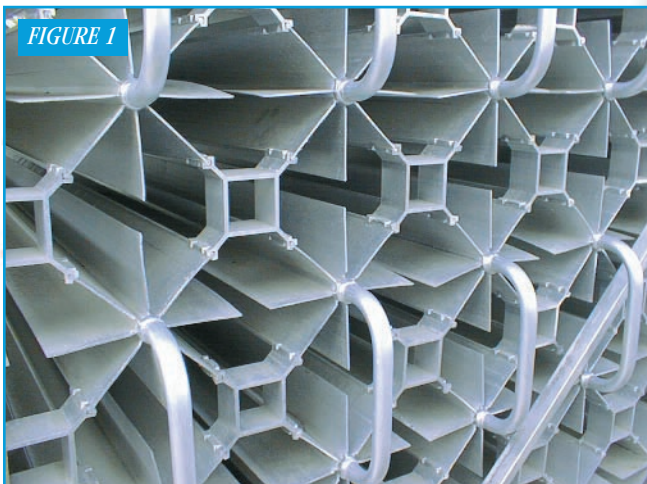

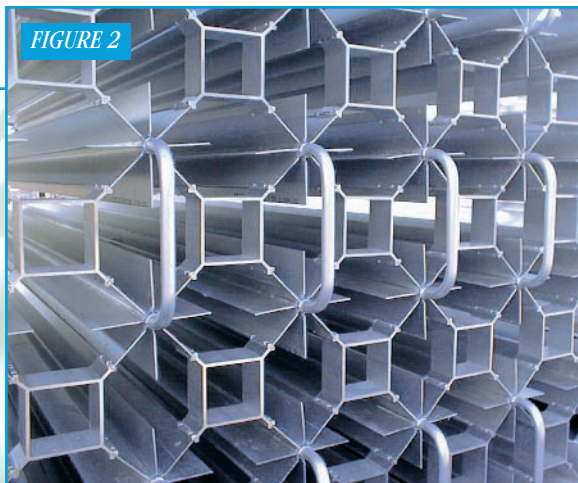

FIGURE 2

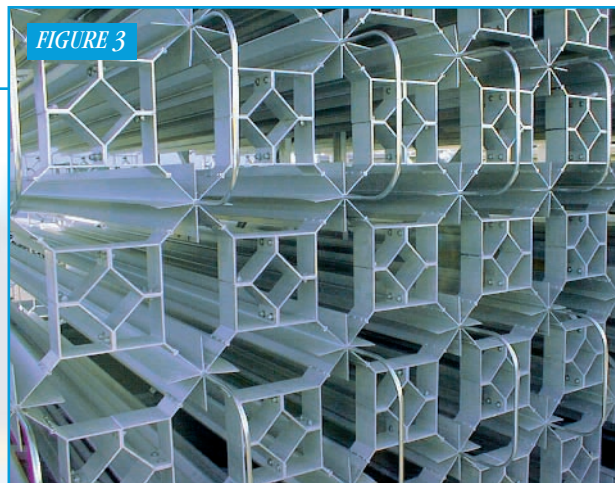

FIGURE 3

zone, is very suited to the ambient air temperature driving force available. Generally, the same rules apply with regards to what flow natural draft and forced draft ambient air vaporizers become economical choices.

The main difference between this climate zone as compared to the tropical zone is the low moisture content that can exist six to nine months of the year. Several unique weather characteristics result from this. Infrared radiation mostly escapes from the atmosphere at night resulting in possible colder nighttime or early morning temperatures; a consideration when designing approach temperatures for this period and ensuring minimum temperatures remain above minimum values. The benefit of this drier climate is longer switching cycles. Typically, switching less than every eight hours has little benefit, but switching should probably be done before 24 hours to obtain maximum efficiency out of the units.

Humid Continental Climate Zones

The humid continental climate zone covers a vast area. In the northern hemisphere, typical areas include the interior United States, Southern Canada, Central Europe, and Central Asia. These areas are characterized by somewhat tropical dew point temperatures in the summer and extended cold, dry periods in the winter, with a combination of the two in spring and fall.

The point where forced draft ambient air vaporizers become more economical over

natural draft vaporizers is much less apparent and must be analyzed more rigorously due to the larger variations in ambient conditions. A phenomenon known as the freeze period (the period of time in which ambient temperatures remain below freezing) is one key to vaporizer specifying.

Typically, fan-assisted vaporizers will require an external energy source in order to defrost during their off period. Electrical heater assemblies or gas fired external air heaters can be used. Because of these additional requirements, the fan ambient vaporizers become less attractive over other vaporizers.

Natural draft vaporizers must be sized such that each bank of on-stream and off-stream vaporizers is capable of operating for one half the freeze period. This could be up to several months in parts of Canada or North Central Asia, thus requiring much more surface area (sometimes as much as four times more) than in other climate zones.

Due to the tropical nature that may exist in these areas during the summer, the switching cycles of these systems is typically based on summer conditions. Because of the potential for very low temperatures during winter months, special equipment additions like gas superheaters may be required downstream of the ambient units depending on pipeline limitations. Lower approach temperatures are often required during winter

months. Fluids such as carbon dioxide and propane that may be vaporized in tropical zones by utilizing ambient units should not be considered in humid continental climates since it is more likely you will be subcooling during winter periods.

Marine Climate Zones

Marine climate zones pose a unique challenge to ambient air vaporizer designers. Some areas included in this zone are Britain, the northwest coast of the United States, British Columbia, Canada, the far northeast of the United States, Maine, Norway, New Zealand, and the southern coast of Argentina. Although ambient temperatures remain relatively mild throughout the year, usually between 23°F (-5°C) and 70°F (21°C), the climate is very moist with dew point temperatures commonly very close to the dry bulb temperatures as well as the freezing point of water. What tends to result is a substantial

...continued on page 7

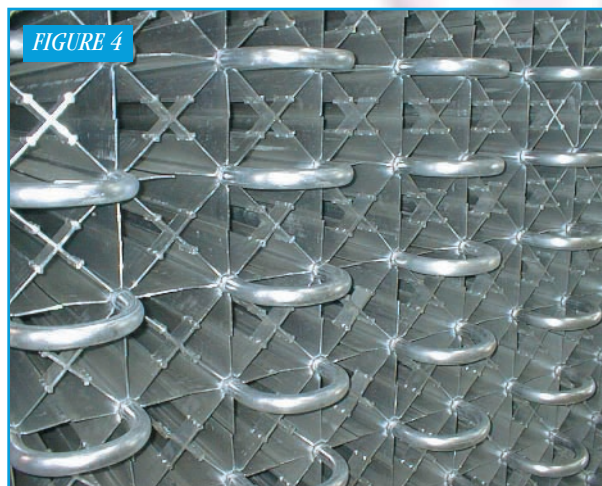

FIGURE 4

The ACD submerged pump is ideal for many applications

ACD'S Model TC-34 submerged pump is a sealess design with integral pump and motor vertically mounted in a sump or tank. The sealess design meets or exceeds all EPA and OSHA standards. The TC-34 is extremely durable and can handle tough pumping requirements, including methane (LNG) and other light-end applications in addition to the more traditional fluids like nitrogen and argon.

The TC-34 is designed to endure thousands of starts per year without requiring an overhaul. The submerged pump's design, unlike conventional trailer pumps, does not include a mechanical seal, which is a major cause of wear and maintenance. Instead, the pump and motor are completely immersed in fluid, allowing the unit to operate for longer periods between overhauls.



ACD has more than 30 years experience designing and manufacturing submerged pumps, from dockside loading pumps to truck mounted units. Recently a larger capacity model was added, the AC-34, allowing for flows to 120 gpm (454 lpm). There are over 260 AC/TC-34 pumps in the field on stand-by or in service.

The AC/TC-34 has many uses in filling applications and the customer benefits from the pump's ability for multiple instantaneous quick starts. Because the pump is immersed in a vacuum-jacketed sump where it is continuously flooded in a liquid, the traditional waiting period for the pump to cool down is eliminated. Providing more deliveries per day with lower product losses results in maximized profits.

The AC/TC-34 in argon service provides the most benefits to the customer by eliminating cool down time of the pump without product loss. When coupled with the proper tank system and with resources saved by not venting expensive argon, the pump will provide a valuable return on investment.



Among other key features of the AC/TC-34 are the product-lubricated bearings and motor, which both benefit from immersion in the cryogen. Diverting and filtering a portion of the pumped product flow through the bearings provides longer bearing life and pump operation. At the same time, the cooling effect of the cryogen makes it possible to reduce the motor's physical size. The pump is also fitted with a state-of-the-art inducer to provide minimal NPSH required for the pump to operate without cavitation. The AC/TC-34 is normally driven by a variable frequency drive controller for greater flexibility as it relates to variable flows and differential pressures as well as reducing speed to obtain a positive flow in extremely low NPSH conditions.

For more information contact Denis DePierro at ACD, tel +1.949.261.7533 or ddepierro@acdcom.com.

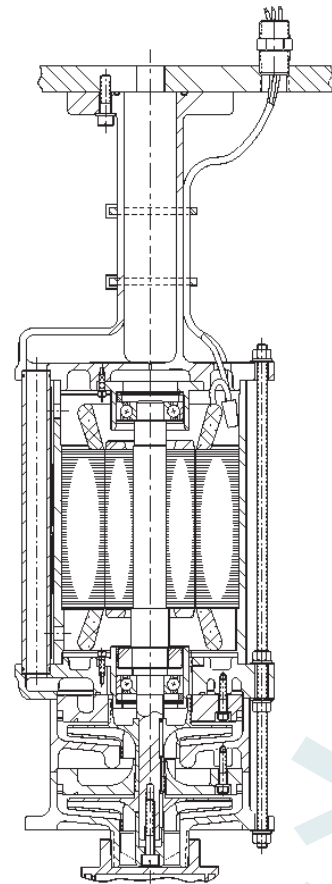

Climate affects the selection of ambient air vaporizers

...continued from page 5

amount of condensation and added precipitation on vaporizer surfaces that quickly freeze into dense pockets of ice, reducing vaporizer capacity. Extra surface area must be added to reduce the effects of this atmospheric phenomenon. Likewise, the vaporizers need to be switched much more often to prevent the formation of very dense ice that will not defrost during off periods if levels get too substantial. Often vaporizers must be sized based on two to three day ratings, but switched every two to six hours to prevent ice buildup.

Micro Climate Zones

Micro climate zones exist in every one of the zones discussed. They are defined as zones that may result in substantially different weather conditions and may exist at distances as close as 31 miles (50 km) from one to the other. Micro climate zones may have unique wind or precipitation design requirements. An example is the area downwind of the Great Lakes region in the United States, where major snow fall accumulations can occur when dry cold winds move over warmer moist lake air causing the air to become saturated and creating localized "lake effect" snow. Other common weather phenomenon such as the Chinook winds of Montana, the buran winds of Russia and Central Asia, the bora winds of the Northern Adriatic coast of Yugoslavia, and the Santa Ana winds of Southern California may result in special mechanical design requirements or height limitations due to the severe winds caused by the venturi effects of local mountain canyons. Altitude effects need to be considered as well, with appropriate capacity reduction applied to the vaporizer models.

For more information, contact Patrick Billman at Cryoquip, tel +1.909.677.2060 or pbillman@cryoquip.com.



Headquarters: Cryogenic Industries
25720 Jefferson Avenue
Murrieta, CA 92562 USA
Tel +1.909.696.7840 • Fax +1.909.698.7484
info@cryoind.com • www.cryoind.com



Torrance, CA USA
Tel +1.310.320.5650
Fax +1.310.320.5688
info@cosmodyne.com
www.cosmodyne.com



Houston, TX, USA
Tel +1.281.590.4800
Fax +1.281.590.4801
sales@cihouston.com
www.cihouston.com



Bad Bellingen, Germany
Tel +49.7635.8105.0
Fax +49.7635.8965
service@acdryo.com
www.acdryo.com



Santa Ana, CA USA
Tel +1.949.261.7533
Fax +1.949.261.6285
acd@acdcom.com
www.acdcom.com



Murrieta, CA USA
Tel +1.909.677.2060
Fax +1.909.677.2066
sales.us@cryoquip.com
www.cryoquip.com



Miramar, FL, USA
Tel +1.954.450.5509
Fax +1.954.450.8738
ort37@aol.com
www.cryoind.com



Selangor, Malaysia
Tel +60 (3) 3165.4801
Fax +60 (3) 3165.4798
rmross1@attglobal.net
www.cryoind.com



Sittingbourne, Kent, England
Tel +44.1795.438433
Fax +44.1795.438434
sales.uk@cryoquip.com
www.cryoquip.com



Muenchenstein, Switzerland
Tel +41.61.413.0230
Fax +41.61.413.0233
info@acdryo.com
www.acdryo.com



Santa Ana, CA USA
Tel +1.949.724.8636
Fax +1.714.641.1921
sales@cryocal.com
www.cryocal.com



Allentown, PA USA
Tel +1.610.437.1867
Fax +1.610.770.0766
lhimmie@aol.com
www.cryoquip.com



Atlanta, GA USA
Tel +1.404.696.8113
Fax +1.404.696.8116
sales@cryoatlanta.com
www.cryoatlanta.com



Selangor, Malaysia
Tel +60 (3) 3165.4800
Fax +60 (3) 3165.4798
sales.my@cryoquip.com
www.cryoquip.com



North York, Ontario, Canada
Tel +1.416.502.1950
Fax +1.416.502.1952
cryocanada1@bellnet.ca
www.cryocanada.com



Imperial, PA USA
Tel +1.724.695.1910
Fax +1.724.695.1926
pittcryo@pittcryogenic.com
www.pittcryogenic.com



Hangzhou, China
Tel +86.571.888.59026
Fax +86.571.888.59025
hci@mail.hz.zj.cn
www.cryoind.com



Dandenong, Victoria, Australia
Tel +61 (3) 9791.7888
Fax +61 (3) 9769.2788
sales.au@cryoquip.com
www.cryoquip.com



Santa Maria, CA USA
Tel +1.805.928.5757
Fax +1.805.925.3861
mtc@mafi-trench.com
www.mafi-trench.com

Calendar of Events

APRIL 8-10 Detroit, Michigan USA	AWS INTERNATIONAL WELDING EXPO (American Welding Society) tel: 800-443-9353x308 (USA only) townsend@aws.org • www.aws.org
APRIL 22-25 Hangzhou, China	ICCR '03 The 3rd International Conference on Cryogenics & Refrigeration tel: +0086.571.87951771 ICCR2003@cmee.zju.edu.cn • www.cmee.zju.edu.cn/ICCR2003.htm
APRIL 27-29 Orlando, Florida USA	AGA OPERATIONS AND BIENNIAL EXHIBITION (American Gas Association) tel: +1.410.997.0763 aga@epponline.com
AUGUST 17-22 Washington, D.C. USA	ICR 2003 21st Congress International Institute of Refrigeration tel: +1.302.984.9450 www.icr2003.org
SEPTEMBER 2-5 Grenoble, France	EUROPEAN HYDROGEN ENERGY CONFERENCE tel: +33 1 53 59 02 11 • Fax: +33 1 45 55 40 33 afhparis@aol.com • www.afh2.org
SEPTEMBER 18-19 Alaska, USA	SPACE CRYOGENICS WORKSHOP melora@squid.jpl.nasa.gov
SEPTEMBER 22-26 Anchorage, Alaska USA	CEC/ICMC Cryogenic Engineering Conference/International Cryogenic Materials Conference tel: +1.303.499.2299 • fax: +1.303.499.2599
OCTOBER 5-8 Las Vegas, Nevada USA	GAWDA 59th ANNUAL CONVENTION (Gases and Welding Distributores Association, formerly NWSA) tel: +1.215.564.3484 • fax: +1.215.564.2175 gawda@gawda.org • www.gawda.org

© 1997 Randy Glasbergen.

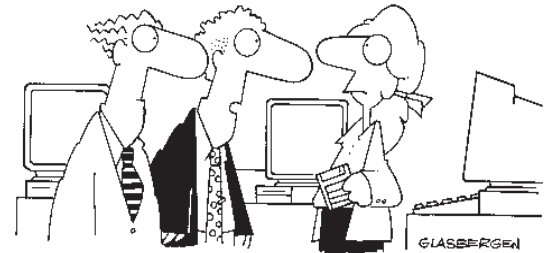

**"We dazzled them with our presentation,
we amazed them with our concepts!
They were all set to sign, but nobody
in our office uses pens anymore."**

**"For the things we have
to learn before we do them,
we learn by doing them."**

—Aristotle

Quote



**CRYOGENIC
INDUSTRIES**

25720 Jefferson Avenue
Murrieta, CA 92562-9524 USA

